



THERMO-BRACE[®], TAPES, AND FLASHING.

INSTALLATION GUIDE

TABLE OF CONTENTS

PRODUCTS & SPECIFICATIONS

- 2** BARRICADE[®] PRODUCTS
- 3** PRODUCT SPECIFICATIONS

THERMO-BRACE

- 4** INSTALLATION

FLASHING TAPE

- 5 - 10** INSTALLATION
- 11-12** FLASHING PENETRATIONS

OTHER

- 13** OTHER DETAILS

BARRICADE® PRODUCTS

THERMO-BRACE®



Thermo-Brace structural sheathing provides racking resistance and may be used as an alternative corner bracing method with structural ratings equivalent or better than OSB.



An all-in-one, insulated, structural, AWRB solution, Thermo-Brace S.I.B. is the ultimate defense against the elements. Versatile, lightweight and superior in strength to OSB, Thermo-Brace S.I.B. combines the insulative power of BASF Neopor® GPS with the strength and racking resistance of Barricade Thermo-Brace to deliver the toughest insulation solution on the market.



Thermo-Brace Utility Board is a non-structural grade approved for use as a draft stop and air barrier. Utility Board is also used for surface protection for floors, counter tops, doors and other surfaces during construction. The poly barriers provide a waterproof barrier to provide further protection against liquids.

FLASHING



A high-performance, asphalt-based window and door flashing tape designed to provide a permanent, weather-tight seal to protect from moisture, leaks, and air penetration.



Our top-of-the-line flashing tape offers the ultimate protection for windows and doors. The 100% butyl rubber adhesive creates a permanent, flexible, weatherproof seal, while the UV inhibitors protect against the sun's harmful rays.



A highly stretchable flashing tape with an aggressive, slower-acting butyl rubber adhesive that conforms around radii and corners while providing maximum protection from water intrusion.



Extremely aggressive, self-adhering flashing membrane designed to protect windows and doors from moisture penetration.

ADDITIONAL MATERIALS



A thin, strong film-coated tape with a cold-weather adhesive system for added protection against energy-robbing air infiltration and exterior moisture penetration.



The perfect partner to Barricade tapes — a flexible, waterproof, door and window sealant for framework and joints.

SPECIFICATION OVERVIEW

	Codes	Composition	Standard Sizes	Optional Sizes	Sheets/ Pallets	Thickness	Required Fasteners
BARRICADE THERMO-BRACE	<i>Green</i> TER 1507-07	High-quality, long-fibered, specially treated water and weather-resistant plies. Plies are pressure laminated. A special water-resistant adhesive is used.	48" x 96" 48 ¾" x 96" 48" x 108" 48 ¾" x 108"	48" x 120" 48 ¾" x 120" 48" x 132" 48 ¾" x 132" 48" x 144" 48 ¾" x 144"	400	0.075"	1 ¼" Galvanized roofing nails, or 16-gauge, 1" min. crown staples with 1 ¼" leg length Red & Green = Structural up to 16" O.C. Blue = Structural up to 24" O.C.
	<i>Red</i> TER 1507-08				315	0.095"	
	<i>Blue</i> TER 1507-09				275	0.120"	
BARRICADE THERMO-BRACE S.I.B. – R3	<i>Green</i> TER 1709-07	Barricade® Thermo-Brace™ with BASF Neopor® GPS	48" x 96" 48" x 108" 48" x 120"	48" x 120" 48 ¾" x 120" 48" x 132" 48 ¾" x 132" 48" x 144" 48 ¾" x 144"	70	¾"	Foam Outward: 1 9/16" x 1 ¾" Leg 16 ga. Staples Foam Inward: 1 ¾" x 11 ga. Smooth Shank Roofing Nail
	<i>Red</i> TER 1703-16						
BARRICADE THERMO-BRACE S.I.B. – R5	<i>Green</i> TER 1709-07	Barricade® Thermo-Brace™ with BASF Neopor® GPS	48" x 96" 48" x 108" 48" x 120"	48" x 120" 48 ¾" x 120" 48" x 132" 48 ¾" x 132" 48" x 144" 48 ¾" x 144"	40	1 1/8"	Foam Outward: 1 9/16" x 2" Leg 16 ga. Staples Foam Inward: 1 ¾" x 11 ga. Ring Shank Roofing Nail
	<i>Red</i> TER 1703-16						
BARRICADE UTILITY BOARD	Meets draft stop and air barrier requirements	High-quality, long-fibered, specially treated water and weather-resistant plies. Plies are pressure laminated. A special water-resistant adhesive is used.	48" x 96" 48 ¾" x 96" 48" x 108" 48 ¾" x 108"	48" x 120" 48 ¾" x 120" 48" x 132" 48 ¾" x 132" 48" x 144" 48 ¾" x 144"	500	0.055"	Staples, nails or screws are recommended.

	Composition	Roll Length	Roll Widths	Rolls Per Case	Total Thickness	Tensile Strength	Application Temperature Range	Operating Temperature Range	Warranty	Nail Sealability	Shelf Life	UV Exposure Rating
BARRICADE FLASH ULTI	Polyolefin faced, peel-and-stick flashing tape using butyl rubber adhesive	75'	4" 6" 9" 12"	6 6 3 4	13.5 mils	60 lb/in	30°F–180°F	-30°F–200°F	20-Year Limited Warranty	Pass	12 Months	Up to 365 days
BARRICADE FLASH CONFORM	Polyolefin film backing, butyl-based adhesive, polyethylene liner	75'	6" 8"	1	50 mils	> 400psi	40°F–180°F	-30°F–200°F	20-Year Limited Warranty	Pass	12 Months	Up to 365 days
BARRICADE FLASH RIGHT	White polyolefin-faced, using SBS asphalt adhesive	75'	4" 6" 9" 12" 18"	9 6 4 3 2	20 mils	12 lb/in (ASTM D412)	40°F–160°F		20-Year Limited Warranty	Pass	12 Months	180 days
BARRICADE FLASH EXTREME	Non-asphaltic, copolymer flashing tape using pressure-sensitive adhesive	75'	4" 6" 9" 12"	12 8 4 4	15 mils		-30°F–150°F		20-Year Limited Warranty	Pass	18 Months	180 days
BARRICADE SEAM TAPE	Polypropylene film coated with a cold-weather acrylic adhesive system	165'	1 7/8" 3"	16	3 mils	30 lb/in	14°F–122°F	-40°F–212°F	20-Year Limited Warranty	Pass	12 Months	180 days
BARRICADE CONSTRUCTION SEALANT	One-component, solvent-free Silyl Modified Polyether (hybrid) sealant	N/A	N/A	24	N/A	N/A	N/A	N/A	1-year Limited Warranty	Pass	12 Months	

THERMO-BRACE® INSTALLATION

FOR BARRICADE® THERMO-BRACE®, THERMO-BRACE® S.I.B. - R3, THERMO-BRACE® S.I.B. - R5

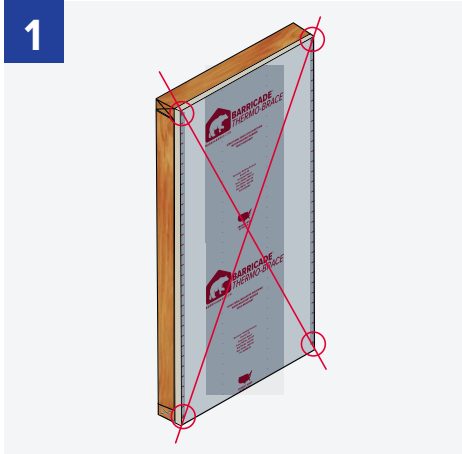

1
DO NOT fasten the four corners first. In order to prevent gaps or rippling, it's important to move horizontally, from one side of the panel to the other, when installing.

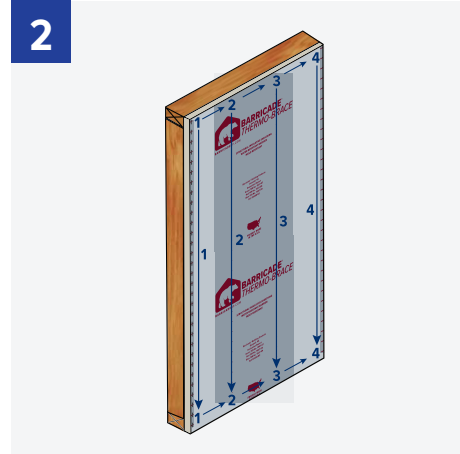

2
Starting at the top left of the panel, begin fastening from top to bottom following the printed fastener schedule (every 3").

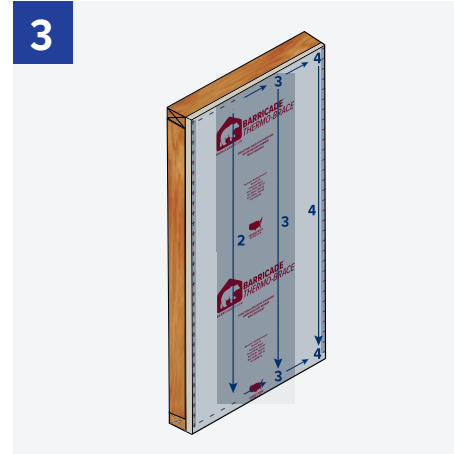

3
Moving across the panel, attach fasteners at the top and bottom of the panel until you reach the next stud. (Note: when using staples, it's important to fasten them in a parallel direction to the stud.)

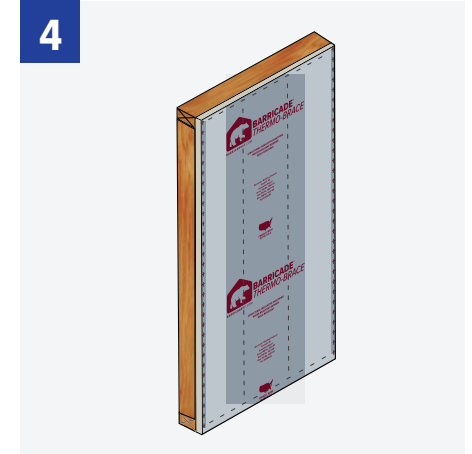

4
Fasten panel in numerical order repeating the procedure described in steps 2 and 3. Continue until the Thermo-Brace panel is properly secured to the frame.

SEAMS & JOINTS

48" sheets should have a slight gap of approximately $\frac{1}{8}$ " between panels at the seams. 48 $\frac{3}{4}$ " sheets are to be overlapped $\frac{3}{4}$ ".

For use as water-resistive barrier (WRB) noted in IRC section R703.2 and IBC section 1404.2, use Barricade® Seam Tape on joints and seams. Overlapped seams do not require tape for use as a WRB.

FOR THERMO-BRACE S.I.B.

Weather-resistant barrier on both sides allows for install with foam side in or out.

R3

Foam Outward:

$1\frac{5}{16}$ " x $1\frac{3}{4}$ " Leg 16 ga. Staples

Foam Inward:

$1\frac{3}{4}$ " x 11 ga. Smooth Shank Roofing Nail

R5

Foam Outward:

$1\frac{5}{16}$ " x 2" Leg 16 ga. Staples

Foam Inward:

$1\frac{3}{4}$ " x 11 ga. Ring Shank Roofing Nail

FLASHING TAPE INSTALLATION

FLANGED WINDOW INSTALLATION

FOR BARRICADE® FLASH RIGHT, BARRICADE® FLASH ULTI, BARRICADE® FLASH CONFORM, BARRICADE® FLASH EXTREME

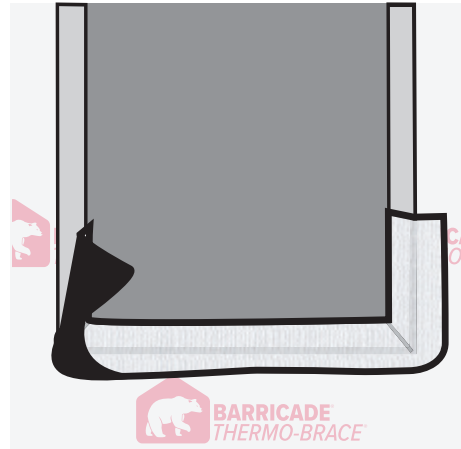
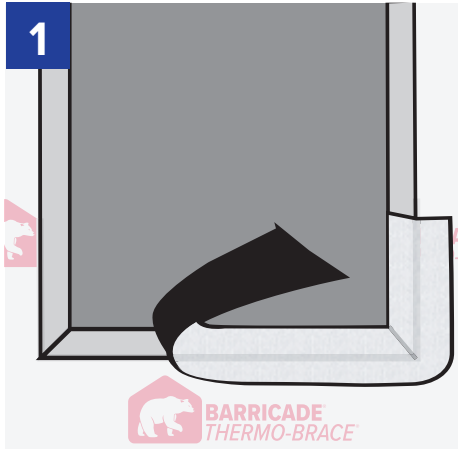

BARRICADE® FLASHING

Prepare sill flashing by cutting Barricade Flash Conform at least 12" longer than the width of the rough opening. Install sill flashing by removing the release paper, centering sill flashing on sill framing stud, and adhering into rough opening. The back edge of Flash Conform should extend to inside edge of sill framing stud and at least 6" up each jamb framing stud. (Sill flashing should not wrap onto the inside of wall.)

DO NOT stretch material along the sill or jamb. When building wrap or conventional building paper is used as a weather-resistive barrier (WRB) over wall sheathing prior to window and flashing installation, Flash Conform should be applied over the WRB after it has been properly cut and folded in and around the window rough opening.

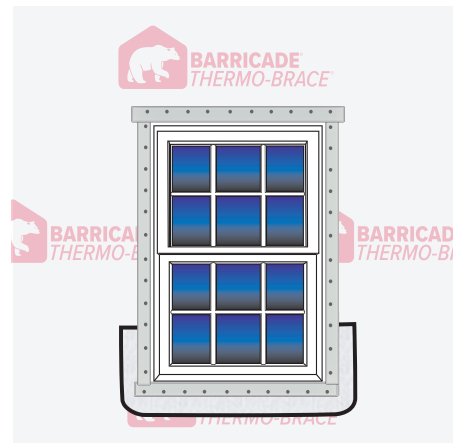
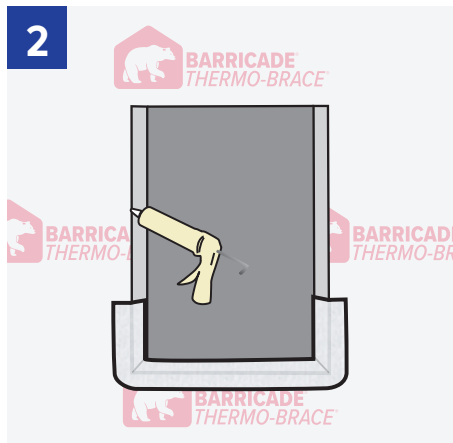

WINDOW AND DOOR INSTALLATION

Before installing the window, either (A) apply a continuous bead of sealant to the backside (interior) of the mounting flange near the outer edge, or (B) apply a continuous seal to the rough window opening at a point to assure contact with the backside (interior) of the mounting flange. DO NOT seal along bottom. Install window according to manufacturer's installation procedures. Use of Barricade Construction Sealant is recommended and compatible with all Barricade Flashing Tapes.

** If using a competitive flashing tape or sealant ensure compatibility.

FLASHING TAPE INSTALLATION

FLANGED WINDOW INSTALLATION

FOR BARRICADE® FLASH RIGHT, BARRICADE® FLASH ULTI, BARRICADE® FLASH CONFORM, BARRICADE® FLASH EXTREME

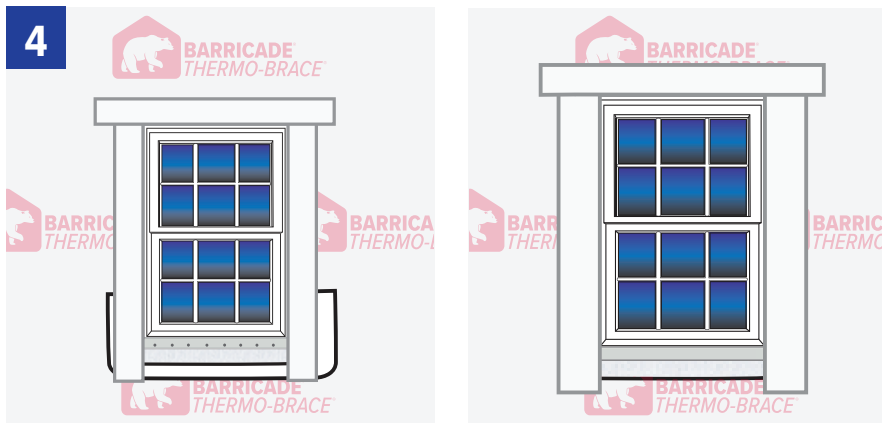
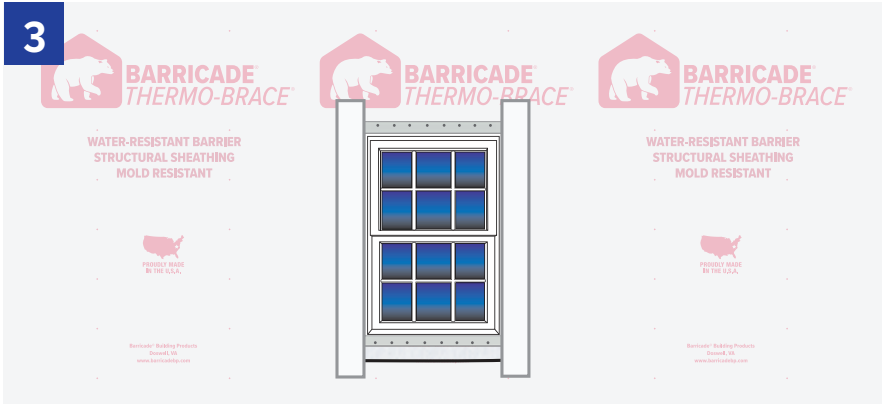

JAM FLASHING

Utilizing a roller to provide firm, consistent pressure, apply Barricade window flashing along vertical sides of the opening. Flash over the side window flanges. Extend the flashing beyond the sill flashing already in place and extend the flashing 1-2 inches beyond the head flange, so that it will not project beyond the head flashing to be applied later.

HEAD FLASHING

Affix the bottom of the head flashing over the mounting flange. Be sure to extend the flashing beyond each jamb flashing. Secure in place by applying pressure. Unattach building wrap and apply over head flashing as shown. Tape all seams and joints.

BEST PRACTICE

On the inside of the window apply a bead of caulking all the way around the window sealing any gaps between the window opening and the window frame. If the gap is larger than 3/8" the use of a foam backer or a low expansion foam is acceptable. Do not use a high expansion foam as it can warp the window frame. When using sealants ensure compatibility with flashing tapes.

FLASHING TAPE INSTALLATION

FLANGELESS WINDOWS

1

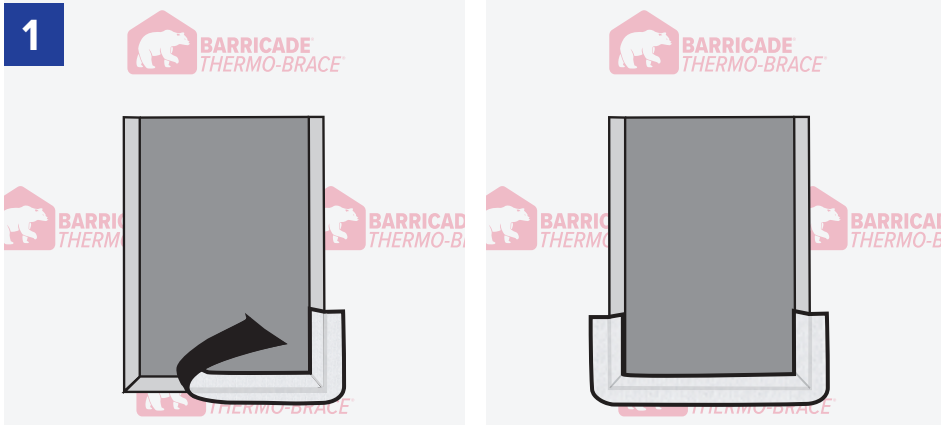

Prepare sill flashing by cutting Barricade Flash Conform at least 12" longer than the width of the rough opening. Install sill flashing by removing the release paper, centering sill flashing on sill framing stud, and adhering into rough opening. The back edge of Flash Conform should extend to inside edge of sill framing stud and at least 6" up each jamb framing stud. (Sill flashing should not wrap onto the inside of wall.)

DO NOT stretch material along the sill or jamb. When building wrap or conventional building paper is used as a weather-resistive barrier (WRB) over wall sheathing prior to window and flashing installation, Flash Conform should be applied over the WRB after it has been properly cut and folded in and around the window rough opening.

2

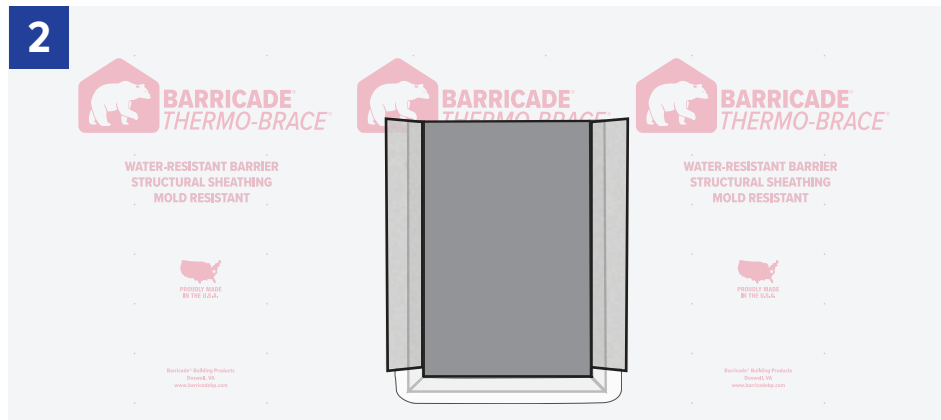

- A.** Cut Barricade flashing material to fit within the vertical length of the rough opening.
- B.** Remove the backing and apply the vertical flashing to cover the wood framing and fold onto the exterior face of the wall adhering to the WRB.
- C.** Ensure that Jam flashing fully overlaps sill flashing.

3

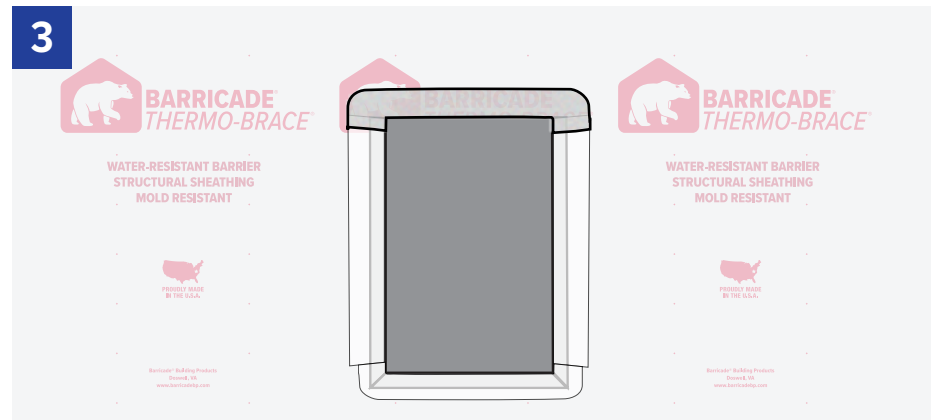

- A.** Cut Barricade flashing material that is at least 12" longer than the rough header opening.
- B.** Remove the backing and align the head flashing with the center interior edge of the header, and adhere to the header and down both vertical jambs.
- C.** Fold and roll the flashing onto the exterior face of the wall. Avoid stretching the material, and work from the center out to the edges and down the jambs.
- D.** Ensure head flashing fully overlaps jam flashing.

FLASHING TAPE INSTALLATION

FLANGELESS WINDOWS

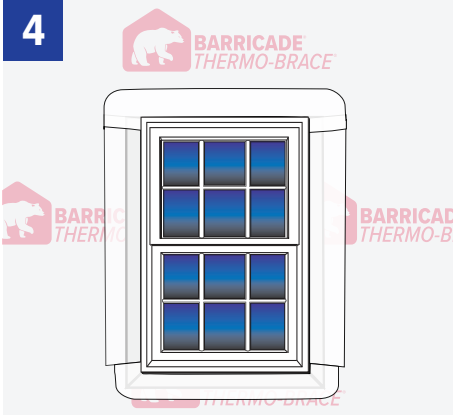

Install and shim window into rough opening per manufacturer's instructions. When using sealants or primers, be sure Barricade branded (or compatible) sealant is used.

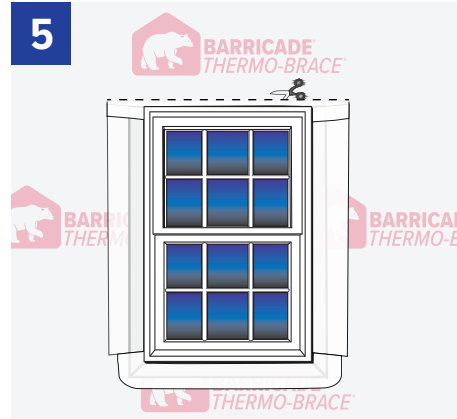

- A.** Release the tape and drape the upper WRB flap onto the window header.
- B.** Trim across the flap to allow at least 1" overlap of the header flashing.

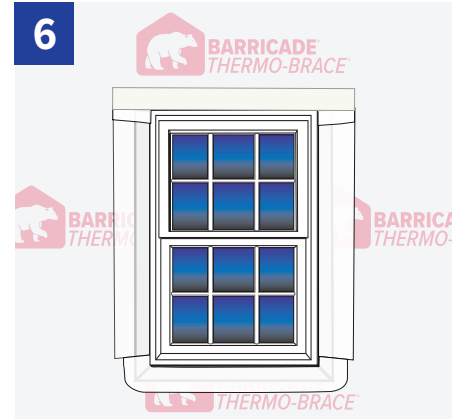

- A.** Apply Barricade flashing over the horizontal flap onto the window face.
- B.** Apply short strips of Barricade flashing to cover the diagonal cuts in the WRB.

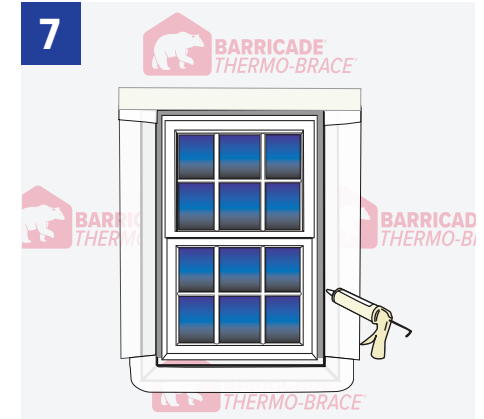

Apply sealant along the top and sides of the window between flashing tape and window frame. Do not apply sealant along the bottom of the window to allow water a place to drain.



Complete the window installation following manufacturer's instructions. Apply a bead of sealant all the way around the window frame and the window opening. If the gap is larger than 3/8" the use of a foam backer or a low expansion foam is acceptable. Do not use a high expansion foam as it can warp the window frame. When using sealants or primers, be sure Barricade branded (or compatible) sealant is used.

FLASHING TAPE INSTALLATION

FLANGELESS DOORS

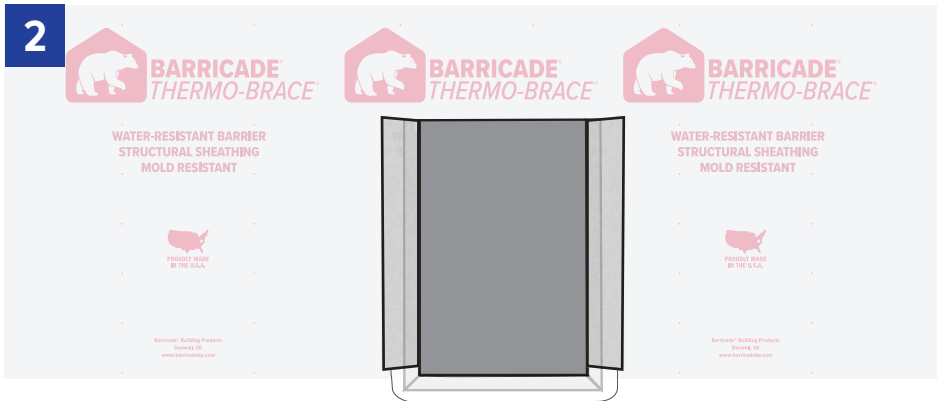
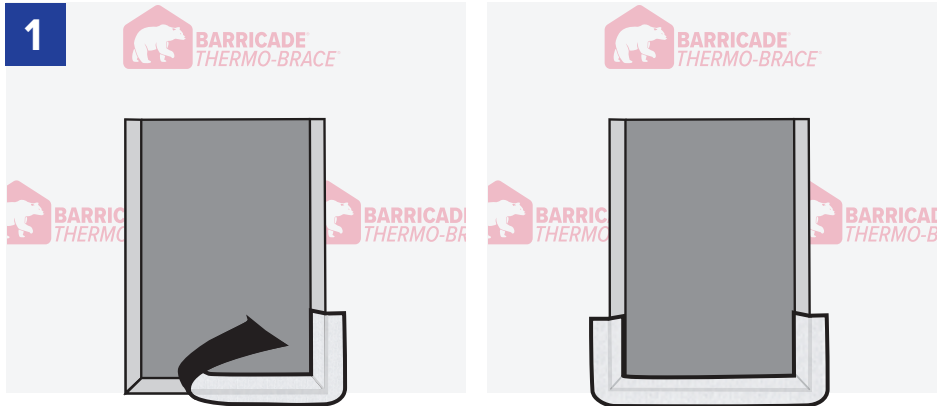

- A.** Cut Barricade flashing material to fit within the vertical length of the rough opening.
- B.** Remove the backing and apply the vertical flashing to cover the wood framing and fold onto the exterior face of the wall adhering to the WRB.
- C.** Ensure that Jam flashing fully overlaps sill flashing.

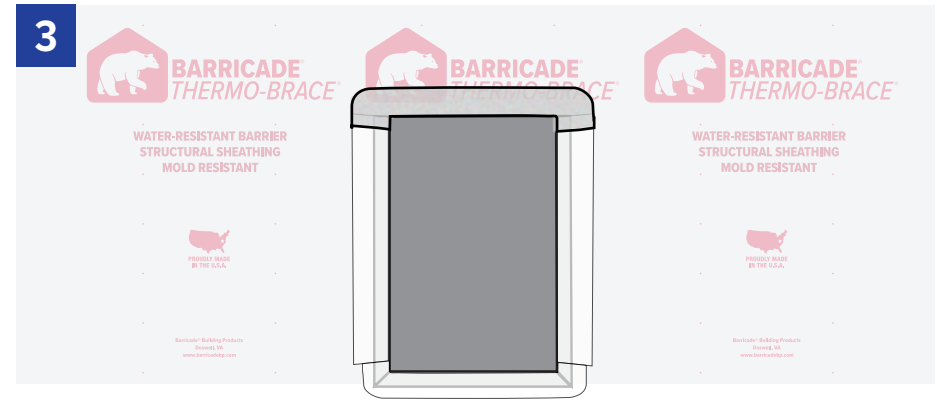

- A.** Cut Barricade flashing material that is at least 12" longer than the rough header opening.
- B.** Remove the backing and align the head flashing with the center interior edge of the header, and adhere to the header and down both vertical jambs.
- C.** Fold and roll the flashing onto the exterior face of the wall. Avoid stretching the material, and work from the center out to the edges and down the jambs.
- D.** Ensure head flashing fully overlaps jam flashing.

Prepare sill flashing by cutting Barricade Flash Conform at least 12" longer than the width of the rough opening. Install sill flashing by removing the release paper, centering sill flashing on sill framing stud, and adhering into rough opening. The back edge of Flash Conform should extend to inside edge of sill framing stud and at least 6" up each jamb framing stud. (Sill flashing should not wrap onto the inside of wall.)

DO NOT stretch material along the sill or jamb. When building wrap or conventional building paper is used as a weather-resistive barrier (WRB) over wall sheathing prior to door and flashing installation, Flash Conform should be applied over the WRB after it has been properly cut and folded in and around the door rough opening.

FLASHING TAPE INSTALLATION

FLANGELESS DOORS

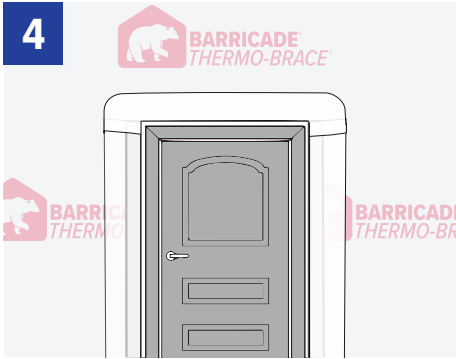

4 Install and shim door into rough opening per manufacturer's instructions. When using sealants or primers, be sure Barricade branded (or compatible) sealant is used.

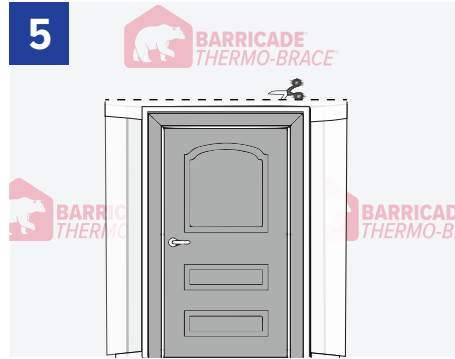

5

- A.** Release the tape and drape the upper WRB flap onto the door header.
- B.** Trim across the flap to allow at least 1" overlap of the header flashing.

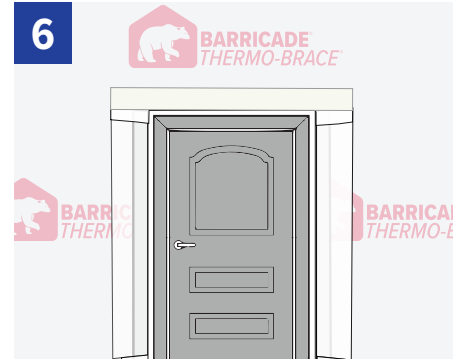

6

- A.** Apply Barricade flashing over the horizontal flap onto the door face.
- B.** Apply short strips of Barricade flashing to cover the diagonal cuts in the WRB.

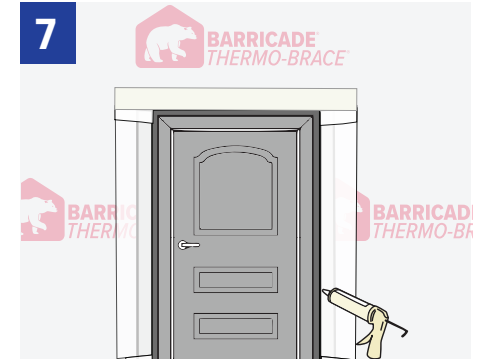

7 Apply sealant along the top and sides of the door between flashing tape and window frame. Do not apply sealant along the bottom of the window to allow water a place to drain.

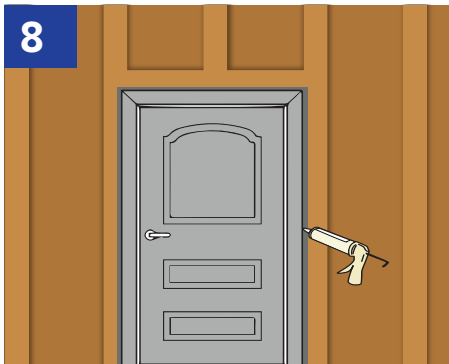

8 Complete the door installation following manufacturer's instructions. Apply a bead of sealant all the way around the doorframe and the window opening. If the gap is larger than 3/8" the use of a foam backer or a low expansion foam is acceptable. Do not use a high expansion foam as it can warp the door frame. When using sealants or primers, be sure Barricade branded (or compatible) sealant is used.

FLASHING PENETRATIONS

WHEN INSTALLED BEFORE THE BUILDING WRAP

SQUARE PENETRATION

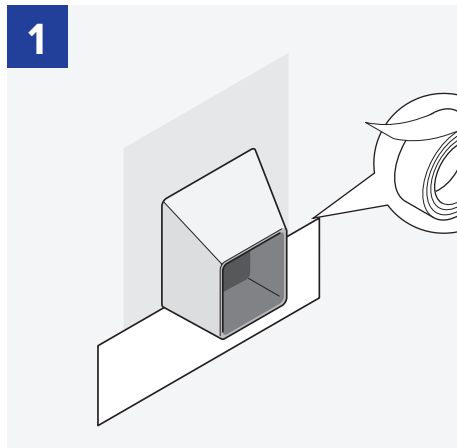

1 Apply Barricade Window flashing to the bottom of the penetration.

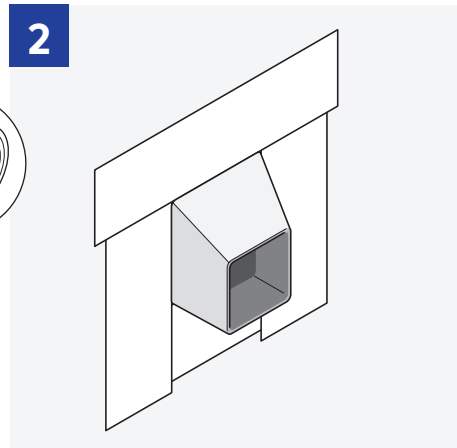

2 Apply Barricade Window flashing along the sides and then the top, shingling each layer.

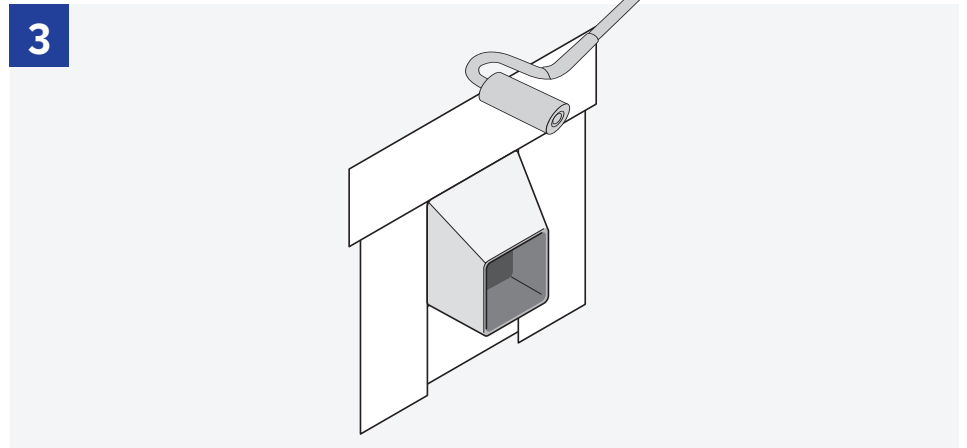

3 Use a roller to apply even pressure along the flashing, being sure to push out any air pockets that may have appeared. Barricade suggests finishing with Barricade Construction Sealant to ensure a tight seal around the edges of the penetration.

ROUND PENETRATION

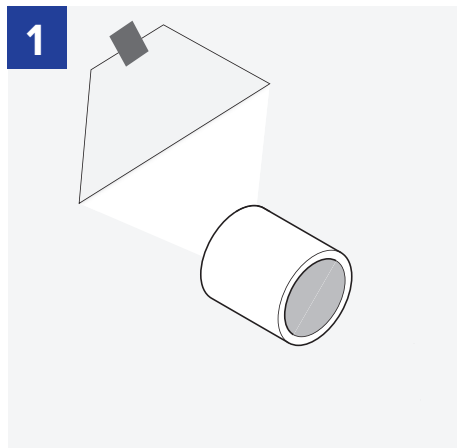

1 Cut two 45° angles and peel back building wrap above the penetration.

Tip: Use Barricade Seam Tape to hold the flap up while not in use.

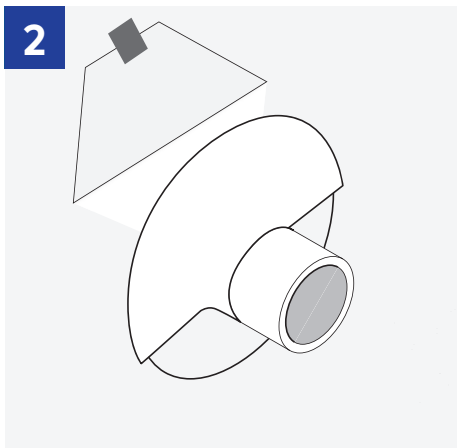

2 Apply Barricade Flash Conform to the underside of penetration, shingling the above side after. Use a roller to apply even pressure along the flashing.

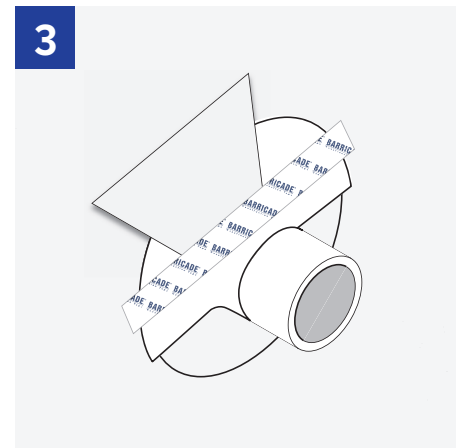

3 Replace building wrap flap over the flashing and tape across using Barricade Seam Tape.

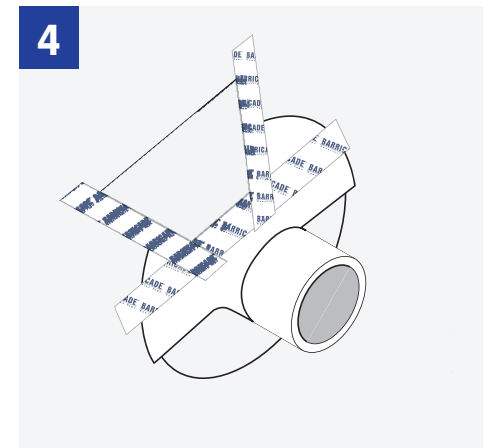

4 Tape over the 45° cuts using Barricade Seam Tape.

FLASHING PENETRATIONS

WHEN INSTALLED AFTER THE BUILDING WRAP

SQUARE PENETRATION

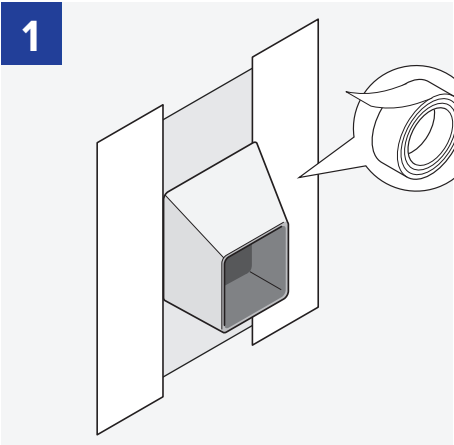
1

Apply Barricade Window flashing along the sides first, leaving the bottom unflashed.

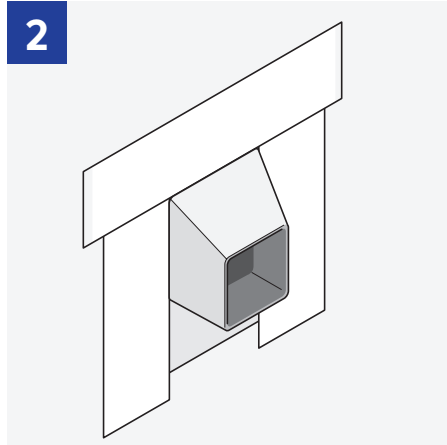
2

Next apply Barricade Window flashing over the top, shingling the side flashing.

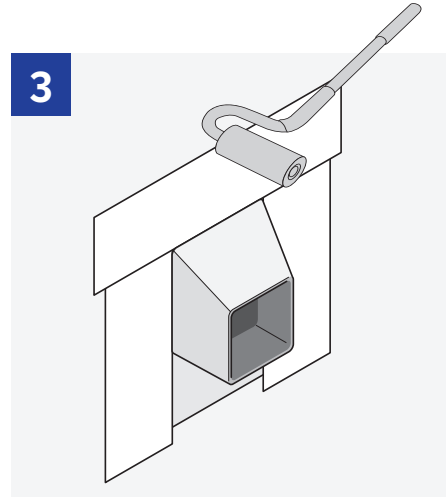
3

Use a roller to apply even pressure along the flashing, being sure to push out any air pockets that may have appeared. Barricade suggests finishing with Barricade Construction Sealant to ensure a tight seal around the edges of the penetration.

OTHER DETAILS:

All installation instructions and procedures contained within this brochure are recommended by Barricade Building Products and should be followed. Failure to follow these instructions and procedures may compromise the integrity of the product and impact its performance.

All Barricade Building Products are manufactured to meet the full intent of all applicable building codes and their governing bodies.

Barricade Thermo-Brace is a weather-resistive barrier (WRB) designed to provide a secondary line of defense against bulk water penetration. It is not

designed or intended for use as a primary waterproofing membrane.

Wind-driven rain can penetrate exterior sidings/cladding such as vinyl, wood, brick, aluminum, hardboard, cementitious, etc. Vinyl and aluminum siding are manufactured with built-in weep holes to allow proper drainage of water that gets past it. Wood, hardboard, and brick exteriors are porous, allowing water to be absorbed into them. Most brick facades also have weep holes built into the wall system to promote water drainage.

Any rips, tears, breaks, holes, etc. that happen during normal construction

should be repaired by taping or patching. Other holes, gaps, or cracks created in the exterior wall around items such as faucets, dryer vents, electrical outlets, etc. should also be properly taped, flashed, and sealed. Any of these occurrences that go unrepaired will diminish the products performance and contribution to the overall water-resistance of the wall system.

It's always a wise construction practice to use and integrate properly installed flashings around all window and door openings as well as other exterior penetrations as part of an overall design strategy to control moisture movement and transport. Please contact your

builder or Barricade Building Products for more details.

The information contained in this installation guide is to the best of our knowledge, true and accurate and is presented in good faith. Barricade Building Products assumes no liability, expressed or implied as to the architecture, engineering, or workmanship of any project. This information may be concurrent with, or superseded by other applicable documents.

Contact Barricade Building Products for further information or technical support at 877-832-0333.

